



# LIFTING EQUIPMENTS



## SEMI ELECTRIC STACKER ESTACKER4M

### Product Profile:

- Manual push stacker with electric motor to raise and lower forks.
- Adjustable fork width to accommodate a variety of different sizes of pallets.
- Cost effective solution for warehouses, distributor centers with a lifting height up to 4 Meters.
- The complete packing consists of stacker, inbuilt battery and charger.
- User friendly and can be operated with very less force and effort.
- Very safe to use and minimum operator licensing requirements in most of the countries.
- High performance and durable body with tight turning radius.

### [Ordering / Usage Information]

220 V	ESTACKER4M
110 V	ESTACKER4M.CA



## Product Specifications

Model No.	ESTACKER4M
Rated load (Q)	1500 KG
Load center (C)	400 MM
Maximum fork height (H)	4000 MM
Maximum height of machine (H2)	4060 MM
Fork length (L)	1000 MM
Outer width of fork (E)	880 MM
Minimum turning radius (R)	1450 MM
Wheelbase (Y)	1185 MM
Front wheelbase lift (X)	316 MM
Lifting motor	12/1.6 V/KW
Battery	12/150 V/AH
Charger	12 /15 V/A
Overall length (A)	1660 MM
Overall width (B)	930 MM
Overall height (H1)	2580 MM
Total Weight	540 KG

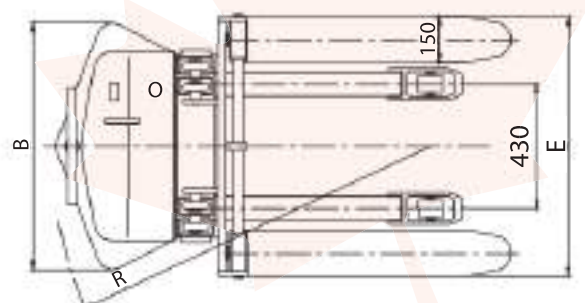
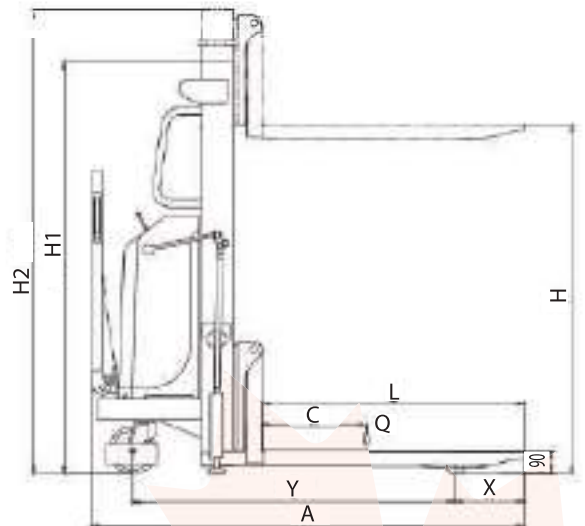

\*Make sure to connect the equipment to the correct power supply (220V/ 110V) depending on the model No.'s